

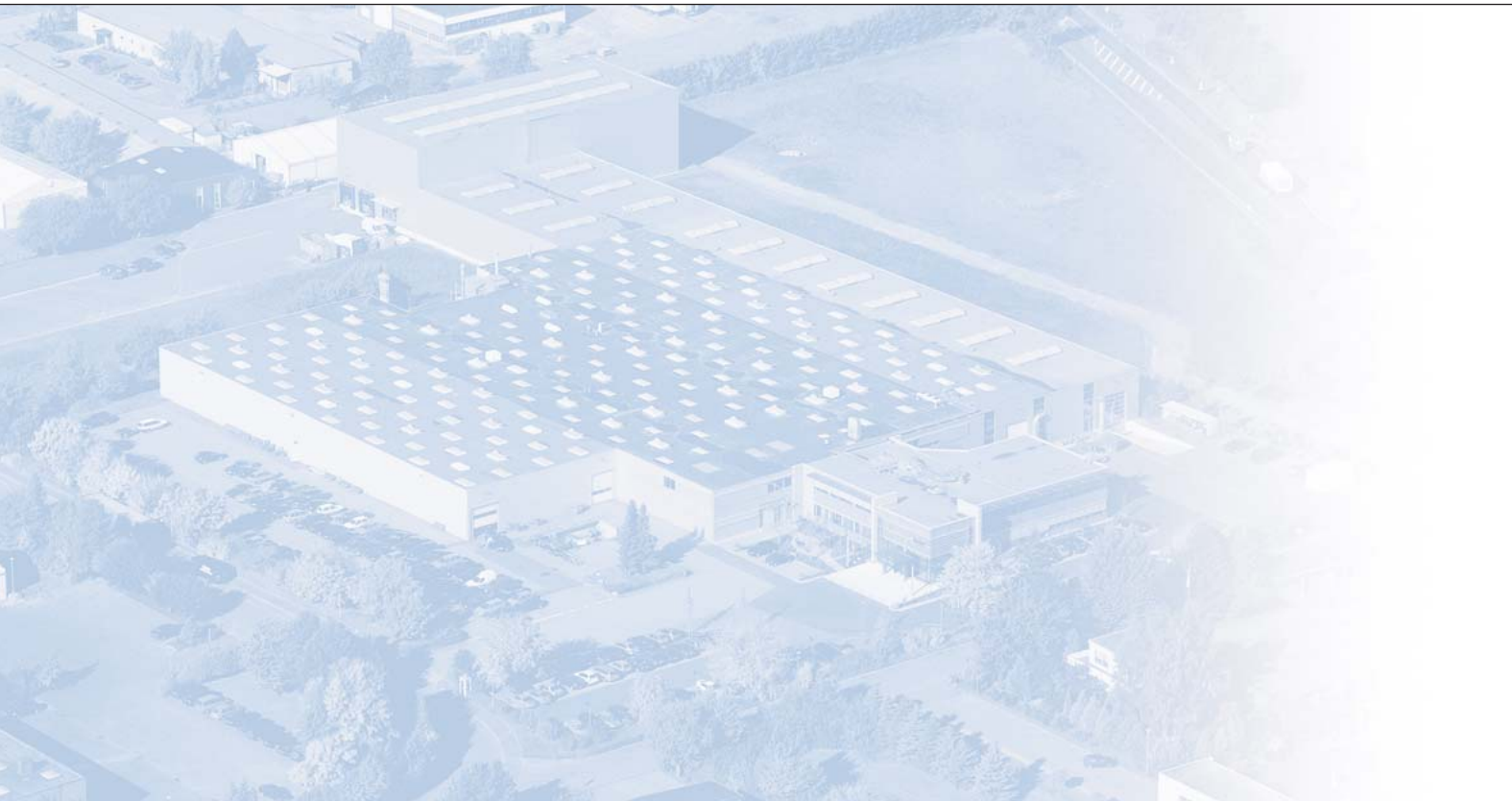

Edge banding machines Ambition 1200 - 1220



A member of the Homag Group of Companies



BRANDT
Kantentechnik GmbH
Weststraße 2
32657 Lemgo
Germany
Tel. +49 5261/974-0
Fax +49 5261/6486
info@brandt.de
<http://www.brandt.de>

PRACTIVE

Intelligent woodworking solutions

HOMAG Group

Success by partnership

To survive in a fiercely competitive market, a company has to have fast, flexible and efficient production. The HOMAG Group, with its sales and service network in over 80 countries around the world, offers you and your employees a strong partnership no matter where you are. The HOMAG Group of companies cover all areas of woodworking and wood-processing. Panel sizing, sawing, edge technology, transportation technology and handling systems are just a few of our specialties.

We also offer solutions for drilling, coating technology, surface technology, plants for doors and doorframes, timber house construction, sanding technology, automation systems, packaging equipment and software. We provide a complete and innovative range of products and services that are always the perfect solution for any requirement.

You, our customers, benefit from high precision, performance and cutting-edge technology.

BRANDT

Perfect edges for demanding customers

We offer our customers innovative and powerful edgebanding machines. Efficiency and quality have the highest priority, and ensure long-term competitive advantages for you. With an annual production of over 2000 edgebanding machines, we are the edgebanding specialist in the Homag Group and the world leader in our market segment. A high degree of standardization in combination with an advanced manufacturing process and more than 50 years of engineering experience

ensure state of the art quality at a superb price-performance ratio. Our clear and structured product range is designed to meet the demands of current and future market trends. All of our developments are focused toward practically-oriented and economic solutions that guarantee you the best possible production results.



„With us, you and your products come first. A promise that you can count on!“

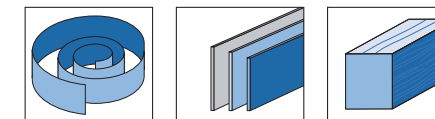

mm	Coil	Strips	Solid
a		min. 70	
b		8 - 50 (option 60)	
c		0,4 - 3 (option 6)	
d		55 (option 65)	

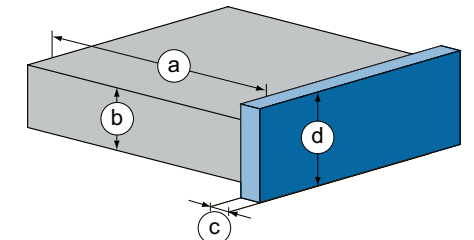

„Ideal prepared for your requirements“

Ambition 1200 - 1220 FC

Small machines to help you grow

The focus for the development of the Ambition 1200 Series was to offer a complete processing solution in the entry level segment, with features which were previously only available on larger machines.

All machines are equipped with a precision gluing unit, a tiltable end trimming unit for straight and chamfer trimming and a multifunctional top/bottom trimming unit. The feed speed of these machine is 10 m / min.

For the complete processing options and a perfect finish, add a joint trimming unit, a contour trimming unit, a radius scraper, a glue joint scraper or a buffing unit.

The right solution for your requirements

The Ambition 1200 series machine leaves nothing lacking. Whether your needs are a demanding shop setting, "batch size one" production for custom requests, living & bedroom furniture or functional office furniture, the Ambition 1200 Series always offers the right solution for your requirements.



The controller – Quality and precision with the touch of a button

Through targeted and constant development of controller technology, simple operation and a high operating comfort are guaranteed.

At BRANDT we focus on you as our customer and your finished product.



EasyControl EC 10+, offering every "plus" for the customer

- + High operating convenience through simple menu format and optimized linepoint adjustment.
- + Fast access to all unit functions through dedicated control buttons.
- + Quick change over to different edgelanding material through user-defined programs.
- + Easy to read large 4-line operating display
- + Clear text error diagnostics provide high operating convenience



Ambition 1220 FC



Ambition 1200



Contact heating shoe

As standard, all machines of the 1200 series are equipped with a contact heating shoe that – optionally activated – transfers contact heat into the board edge directly prior to the glue application to the workpiece edge, this notably optimising the gluing quality, especially with difficult edging materials or at very low ambient temperatures.

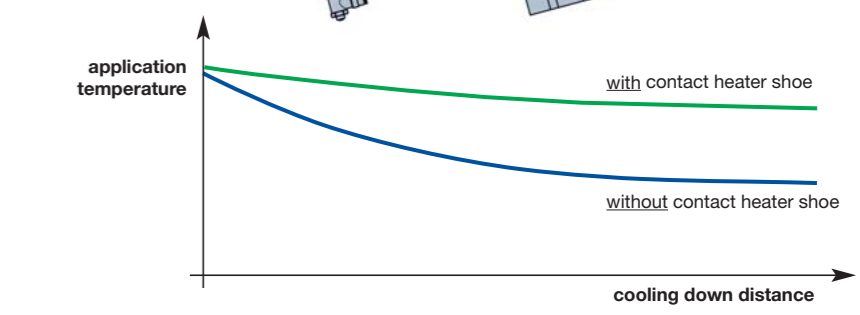
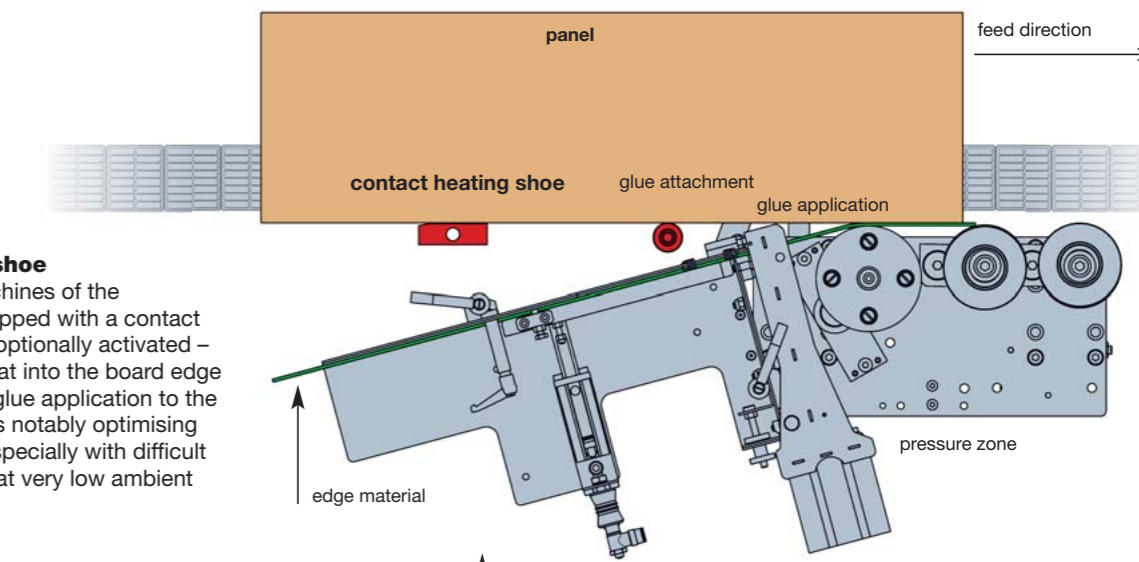

Significant competitive advantages – Pace setting performance and quality



Joint trimming unit
Perfect cut and high operating life due to diamond tipped tools for an optimum edge joint quality.



Gluing unit and magazine
Coil and automatic strip magazine for a reliable edgmaterial supply. Optimal glue joints, by controlling the exact amount of glue.



Pressure zone
Heavy pressure zone up to 3 mm edge thickness and 50 mm workpiece height for an optimal glue joint (optional 6 mm edge thickness by 60 mm workpiece height).



End-trim unit
Chamfer/straight adjustment by easily tilting the unit. (Pneumatic adjustment optional)



Multifunctional trimming unit
Multifunctional trimming unit with DFC tool technology for optimum dust extraction.



Trimming unit with pneumatic 3-point adjustment (optional)
For even more effective production and much shorter changeover time.



Corner rounding unit
Optimum corner rounding without adjustment or set-up, resulting from the coupled diamond tool and tracer roller.



Profile scraping unit
To smooth radii or chamfers (Pneumatic adjustment optional).



Glue joint scraping unit (optional)
For the perfect finish and for edge scraping up to 0,3mm.



Buffing unit
Buffing unit to polish edges and maintain their natural color.



Central lubrication unit (optional)
To lubricate the feed track guidance system to guarantee precision and a long life of the conveyor chain.



Nesting package (optional)
Includes a multi-roller tracing device for the trimming and scraping units to compensate for hinge holes.

Technical Data

Ambition 1200

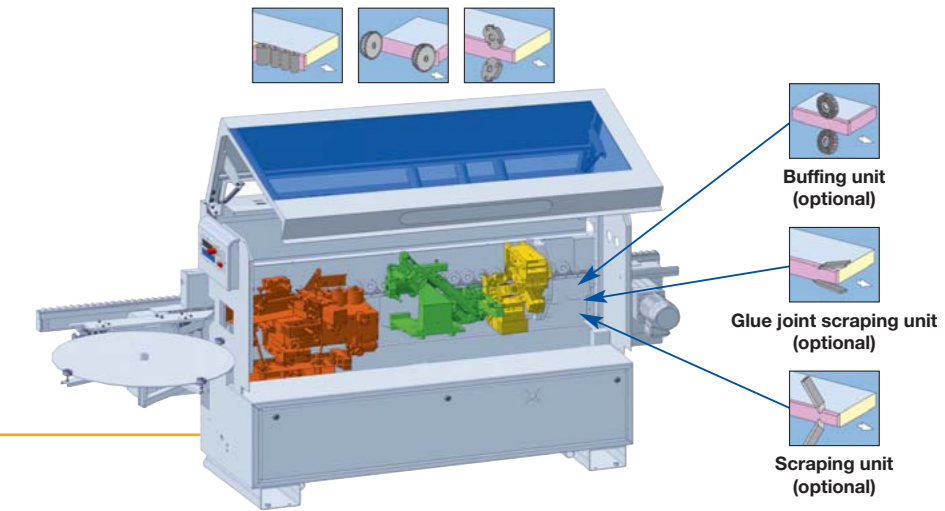

**Ambition 1210
Ambition 1210 F**

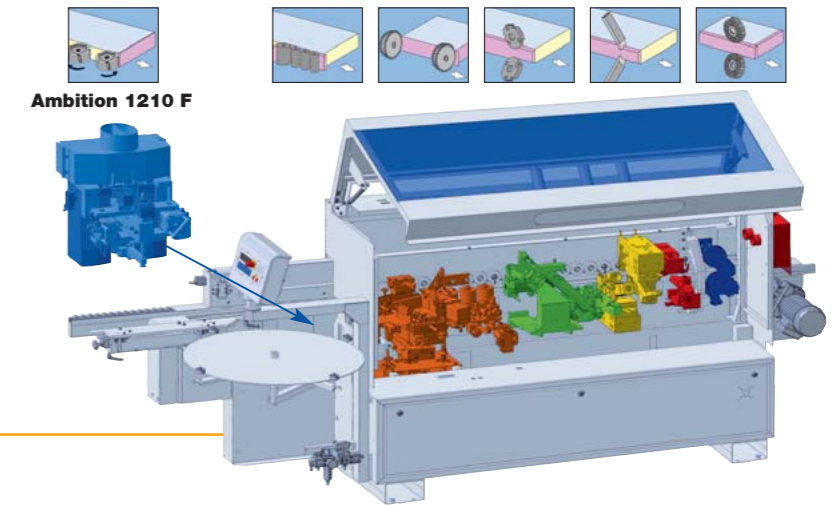

**Ambition 1220 C
Ambition 1220 FC**

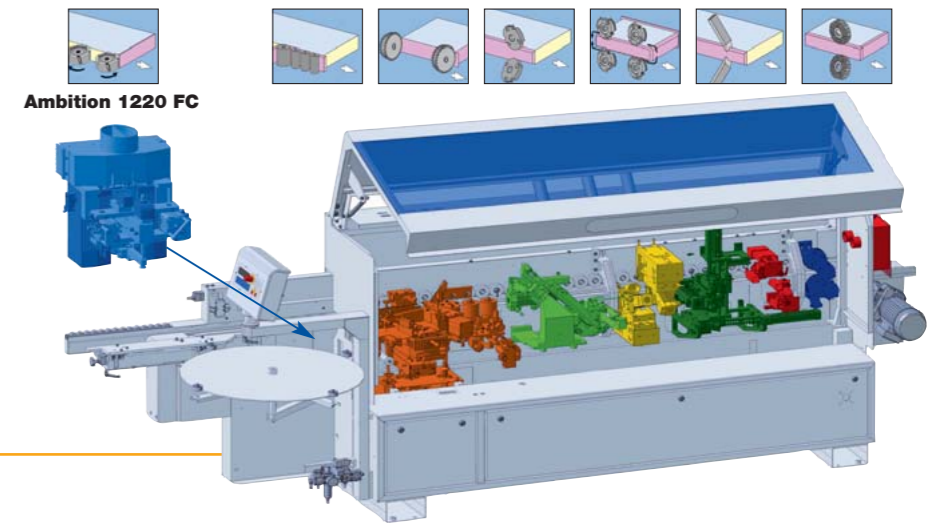

	Ambition 1200	Ambition 1210	Ambition 1210 F	Ambition 1220 C	Ambition 1220 FC
Machine dimensions					
Machine length (mm)	3450	3650	3650	4150	4150
Working height (mm)	950				
Machine dimensions WxH (mm)	1300 x 2180				
Working dimensions					
Workpiece thickness (mm)	8 - 50 (optional 60 mm in combination with 6 mm edge thickness)				
Edge material thickness (mm)	0,4 - 3,0 (optional 6 mm)				
Miscellaneous					
Feed speed (m/min)	10				
Weight (kg)	800	1100	1100	1400	1400
Connected value (kW)	4	4,5	9	5	10
Extraction diameter (mm)	3x60	3x60/1x100	1x120/3x60/1x100	1x120/3x60/1x100	1x120/3x60/1x100
Electrics	400 V - 3 Ph. - 50 Hz				
Pneumatics (bar)	6				

All rights for technical changes withheld. Individual machine pictures may show options.